



sales@cip-ca.com

707-685-8077



Maintenance service and  
installation manual

# QC Series Centrifugal Pump

QC-M02

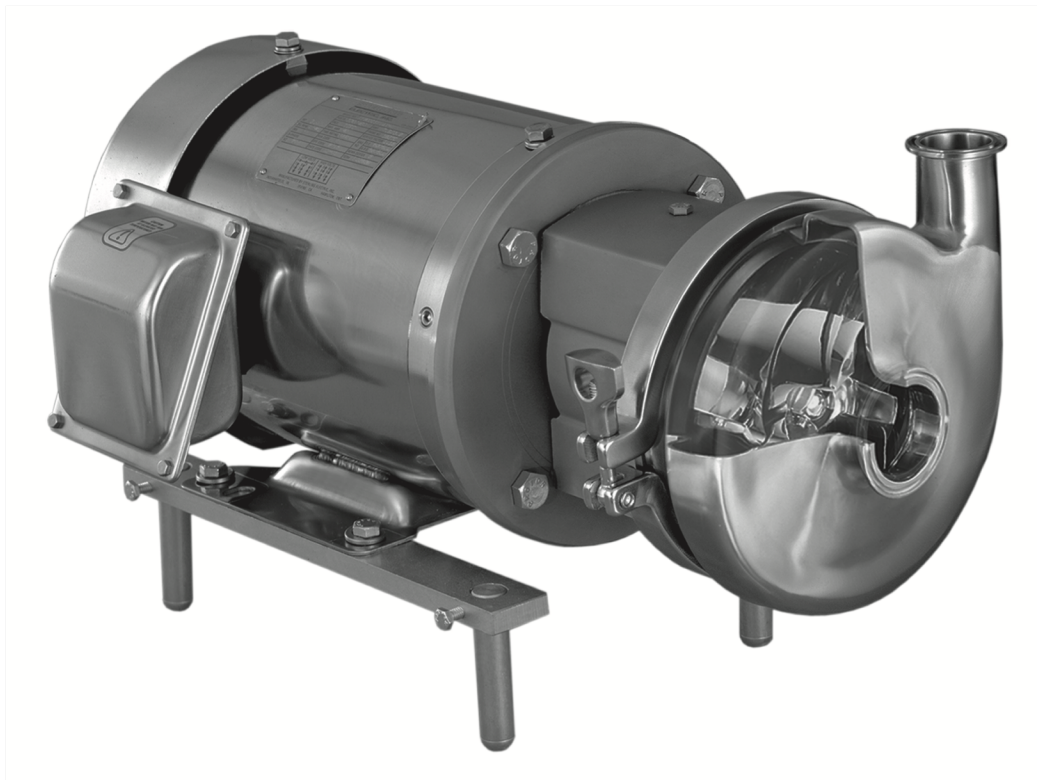

[www.qpumps.com](http://www.qpumps.com)

[support@qpumps.com](mailto:support@qpumps.com)



### Thank you for purchasing a Q-Pumps product!

This manual contains installation, operation, cleaning and maintenance instructions for the QC, QC plus and IC plus series.

It also includes a part list as well as a troubleshooting chart to assist in determining pump mal-function and practical advices for the maintenance and operation of the equipment.

<b>About this Manual</b> .....	<b>3</b>
Q-Pumps Warranty .....	3
<b>Safety</b> .....	<b>4</b>
important safety information .....	4
<b>Installation</b> .....	<b>5</b>
Instalation guidelines .....	5
How to install the piping .....	6
Assembly preliminaries .....	7
<b>Exploded Assembly</b> .....	<b>8</b>
<b>Part List</b> .....	<b>9</b>
<b>Assembly</b> .....	<b>10</b>
Beggining the assembly .....	10
Leg bracket assembly .....	10
Adapter assembly .....	10
Spacing of the impeller and stub shaft .....	11
Assembling and installing the mechanical seal .....	12
Kit plus assembly .....	17
Industrial T21 seal assembly -IC+ series .....	18
General assembly inspection .....	19
Impeller retention .....	19
Casing assembly .....	20
Before turning on the pump .....	20
<b>Common Problems</b> .....	<b>21</b>



## ABOUT THIS MANUAL

To ensure the best performance of your pump, please read this manual before starting it. You will find useful information and instructions for the assembly and disassembly procedures required for the necessary pump maintenance.

For any questions related to the operation, maintenance or installation, please contact your local distributor or directly to Q-Pumps:

Q-Pumps S.A. de C.V.  
Acceso "A" #103, Fracc. Industrial Jurica  
Querétaro, Qro., México, 76130  
Call: +52 (442) 218 4570 y +52 (442) 103 3100  
Fax: +52 (442) 218 4577  
E-mail: support@qpumps.com  
Web: www.qpumps.com

The information in this manual might change without notice, we recommend to visit our website for any updates.

### **Q-Pumps S.A. de C.V. Warranty**

Q-Pumps guarantees that all manufactured and sold products are free from defects in materials and manufacture for a period of one (1) year from the date of shipment. The warranty does not apply to products which require repair or replacement due to what is considered normal wear. Conditions caused by normal wear include (but are not limited to standard rotors wear) casing, mechanical seals, gears and bearings wear.

Accidents, operating errors or improper maintenance are not covered by the warranty. Q-Pumps assumes no liability for incidental, accidental or consequential damages. The purchaser by acceptance of delivery assumes all liability for the consequences of use or misuse by it, its employees or third parties. Unless they are approved in advance, Q-Pumps does not assume any costs related to parts and / or service.

Q-Pumps disclaims any responsibility for modifications or conversions to the pump and the system. For security reasons and functionality use original parts only. The use of other parts voids the warranty and excludes liability for any consequences.

The pump is designed only for pumping fluids under established characteristics in the selection sheet. Any other use besides the intended one without the prior written consent of the manufacturer's application, will result in disclaim of any responsibility from Q-Pumps.

If the pump is stored temporarily or indefinitely, avoid weather exposure and protect the connection ports with plastic plugs supplied with your pump. Turn the pump shaft by hand every two months to change the rotating position of the bearings.

## **IMPORTANT SAFETY INFORMATION**

**Safety is very important!**

**DO NOT attempt to modify any Q-Pumps product**, the QC series centrifugal pumps have been designed to be safe and reliable, to do so could create unsafe conditions and void all warranties.

**DO NOT place any Q-Pumps product in an application where general product service ratings are exceeded.** If the maintenance and operation personnel do not observe the instructions in this manual could result in personal injury or machine damage.

The following **DANGER, WARNING, and CAUTION** signs and their meanings are used within these instructions to avoid serious injury and/or possible damage to equipment.

 <b>DANGER</b>
<p>Indicates an imminently hazardous situation which, if not avoided, will result in death or serious injury. The word danger is used in the most extreme cases.</p>

**CODE 136530001**  
(Rotating direction ccw)



 <b>WARNING</b>
<p>Indicates a potentially hazardous situation which, if not avoided, could result in minor or moderate injury. May also be used to alert against an unsafe operating or maintenance practice.</p>

**CODE 136530002**  
(Guard warning)

<p><b>WARNING</b></p> <hr/> <p><b>ROTATING SHAFT</b></p>
<p><b>DO NOT OPERATE WITHOUT GUARD IN PLACE</b></p>

 <b>CAUTION</b>
<p>Indicates a potentially hazardous situation which, if not avoided, could result in death or serious injury.</p>

Safety labels are placed on every pump. **DO NOT** remove any labeling on any Q-Pumps product. Replace any label that is missing.

## **DESCRIPTION**

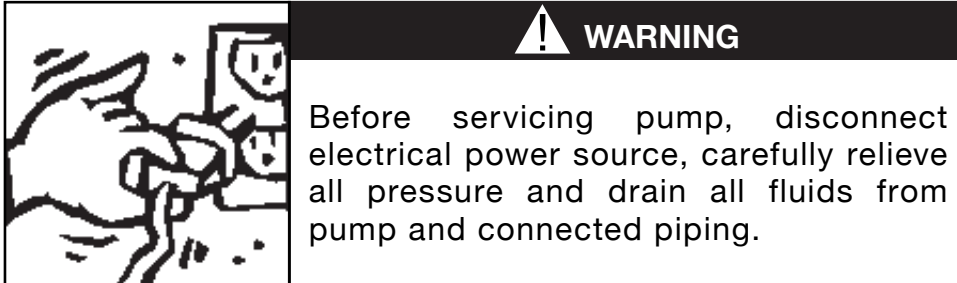

### **Before servicing pump, disconnect electrical power source.**

The QC series closed-coupled pumps are made up of two sections, power or drive section and the liquid end or pump section.

The pump is mounted to the frame of the drive motor by means of an adapter, and is coupled to the motor shaft. The impeller mounts on the stub shaft and is retained by one of the three methods. The casing is clamped to the adapter, greatly simplifying removal, and also permitting positioning of the discharge outlet through 360°. The external, balanced seal assures long seal life. The drive motor is mounted on a frame having adjustable legs providing simple installation and leveling.

## **INSTALLATION GUIDELINES**

### **UNPACKING EQUIPMENT**

Check the contents and all wrapping when unpacking your equipment. Inspect all parts for damage that may have occurred during shipping. Report any damage to the carrier.

### **LOCATION AND INSTALLATION**

The pump unit should be located as near as possible to the liquid source and in a position where the suction piping can be short and direct with a minimum number of elbows and fittings. It should also be readily accessible for inspection and cleaning.

The pump unit as received from the factory is ready for installation. To install it, attach a hoist if necessary, loosen the set screws in the adjusting leg brackets, and individually adjust the legs until the pump is leveled. Tighten the set screws.

Attach the suction and discharge piping. Be sure suction and discharge piping is properly supported to avoid any strain on the pump casing.

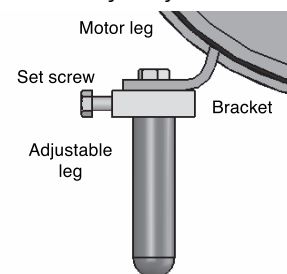

## HOW TO INSTALL THE PIPING

### GENERAL

This section provides some do's and do not's of piping which will aid in obtaining the maximum efficiency and service from your pump. Piping should be independently supported at both the suction inlet and discharge outlet. Care should be taken that piping is properly aligned and does not put any strain on the pump casing. The piping should have as few bends as possible.

### SUCTION PIPING

The suction piping should be short and follow a direct route with a minimum number of elbows and fittings. Elbows should be located as far as possible from the suction inlet to prevent head loss due to increased friction. Excessive friction losses in the suction line could result in pump cavitation, causing poor performance, noise, vibration, damage to equipment and possible damage to fluid.

Whenever possible the diameter of the piping at the suction inlet should be increased in size, an eccentric tapered reducer should be used instead of a concentric tapered reducer to prevent air pockets from forming and impairing pump efficiency. In turn, the eccentric reducer may be placed at the inlet of the pump and should be positioned so the straight side is up. A horizontal suction pipe must have a gradual rise to the pump. A high point in the suction line will form an air pocket and prevent proper pump operation. All joints in the suction line should be air tight, to prevent air leakage which can reduce pump capacity and efficiency.

### DISCHARGE PIPING

Position of the pump discharge is preferably either vertical or top horizontal. The discharge piping should be short and direct with a minimum number of elbows and fittings. Elbows should not be used at the discharge outlet, as the friction encountered would be increased, resulting in head loss. However, use of a large discharge pipe than recommended may reduce the total pump head, but increase the pump volume, which can cause pump vibration due to overload. Use of a discharge pipe smaller than the pump discharge outlet increases the total pump head but decreases the volume. If a reducer is required on the outlet port of the pump and the discharge is vertical a concentric reducer should be used. If the discharge is horizontal an eccentric reducer should be used and should be positioned so the straight side is down.

### LOCATING VALVES

In suction lift applications where the lift is not very high, it may be desirable to install a foot valve, to facilitate priming, and to prevent draining off of the liquid back to the source. A throttling valve should be installed in the discharge piping to provide control pump flow rate and prevent motor overload.

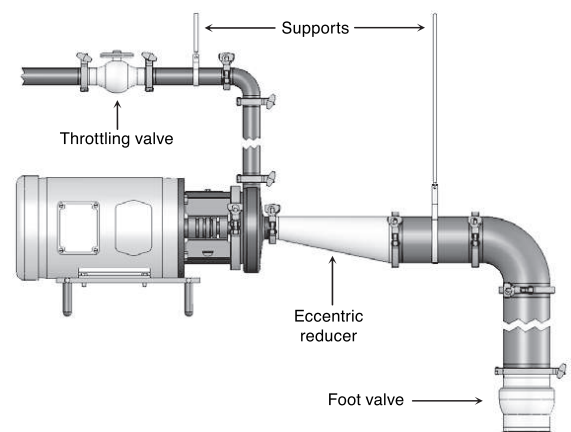

## **ASSEMBLY PRELIMINARIES**

	<p style="text-align: center;"><b>! WARNING</b></p> <p>Before servicing pump, disconnect electrical power source, carefully relieve all pressure and drain all fluids from pump and connected piping.</p>
---	---

Before beginning the assembly procedure identify every element that is going to be installed, you can use the exploded view and part list shown in pages 6 and 7. During the assembly you may need the following tools:

1. 1", 3/4", 9/16" and 1/2" Wrenches.
2. 1/8", 5/32", 3/16" and 1/4" Allen wrenches.
3. Rubber mallet.
4. Caliper, useful when assemble seal type "E".
5. 5/8" & 7/8" Socket – for impeller nut, for QC plus models.
6. 3/8" diameter steel rod – to hold stub shaft plus, for QC plus models.
7. Torque Wrench

Recently it has been added new series to the known QC series: the kit plus, QC plus series and IC plus series for every specific applications. There are some modifications in the assembly in each one of these series without altering the operation of the equipment.

### **KIT PLUS (KIT+)**

It is made up by a stub shaft plus, a stub shaft collar, a shaft key, an impeller plus, an impeller nut, front and back impeller gaskets. The collar may use one or two screw according to the pump model. This assembly works exactly the same as a standard assembly from the QC series.

### **QC PLUS (QC+) SERIES**

The QC plus series have been development to facilitate the assembly of the QC series pumps offering some advantages. QC plus series have a better subjection when mounting the stub shaft onto the motor using a collar. The stub shaft plus is threaded and offers a better assembly to the impeller by means of a key and a nut to obtaining an assembly designed to meet the 3A regulations. An ordinary QC series pump can be turned into a QC plus series with a Kit plus.

### **IC PLUS (IC+) SERIES**

Series IC plus is a modality of the QC series plus for industrial purposes. It uses an internal mechanical seal denominated **T21** which lodges in an industrial back plate. Because of this series is industrial does not meet the 3A regulations. No other type of mechanical seal like "D", "DG", "E" or "F" seals from the QC series is compatible with the IC plus series. An ordinary QC series pump can be turned into a IC plus series with a Kit plus, an industrial back plate and a mechanical seal type **T21**.

**EXPLODED ASSEMBLY**

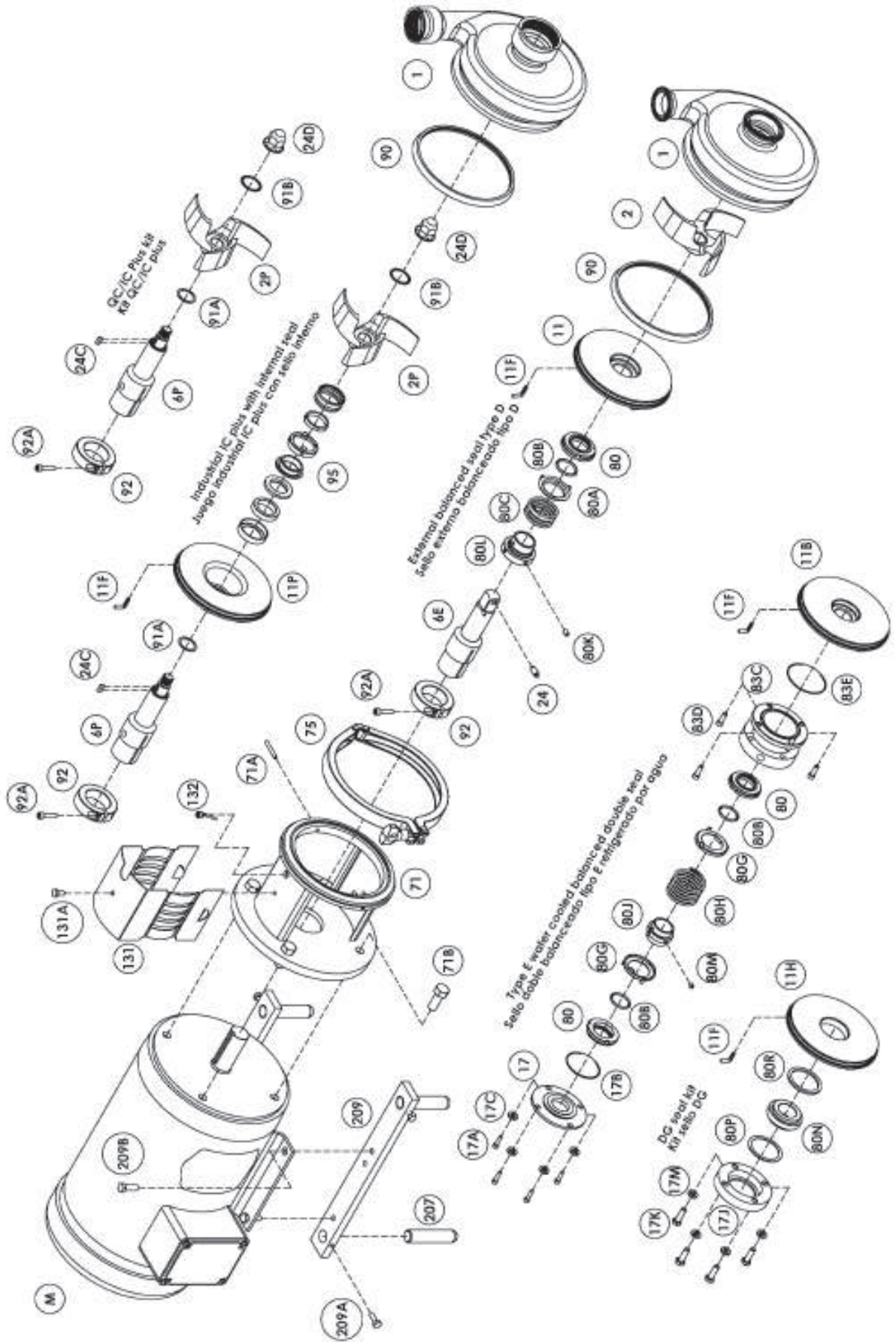



## **PART LIST**

<b>External balanced seal type D</b>		
11	Backplate "D"	1
11F	Backplate pin	2*
80	Carbon	1
80A	Cup seal "D"	1
80B	O-ring carbon	1
80C	Spring seal "D"	1
80K	Set screw collar seal "D"	2
80L	Drive collar "D"	1
<b>Clamped-in seat seal type DG</b>		
11F*	Backplate pin	2*
11H	Backplate "DG"	1
17J	Gland ring "DG"	1
17K	Bolt/screws gland ring	4**
17M	Lock washer	4**
80N	Seal seat "DG"	1
80P	PTFE gasket	1***
80R	PTFE gasket	1***
<b>Leg brackets</b>		
207	Adjustable leg	4
209	Adjustable leg bracket	2
209A	Set screw	4
209B	Bracket mounting screw	4
<b>Kit plus</b>		
2P	Impeller plus	1
6P	Stub shaft plus	1
24C	Shaft key plus	1
24D	Nut plus	1
91A	Back gasket plus	1
91B	Front gasket plus	1
92	Drive collar plus	1
92A	Bolt drive collar	1**

\* Not necessary in some models

\*\* Quantity may vary with model

\*\*\* Not interchangeable

## **Water cooled balanced double seal type E**

11B	Backplate "E"	1
11F	Backplate pin	2*
17	Follower	1
17A	Machine screw	4**
17B	O-ring	1
17C	Lock washer	4**
80	Carbon	2
80B	O-ring	2
80G	Cup seal "E"	2
80H	Spring seal "E"	1
80J	Drive collar "E"	1
80M	Set screw drive collar "E"	2
83C	Stuffing box "E"	1
83D	Machine screw	4**
83E	O-ring	1
<b>Industrial Kit plus</b>		
	Kit plus	1
11F	Backplate pin	2*
11P	Industrial backplate	1
95	Seal T21	1
<b>Common components</b>		
1	Casing	1
2	Impeller	1
6E	Stub shaft	1
24	Retainer (impeller)	1
92A	Bolt drive collar	1
71	Adapter	1
71A	Adapter pin	2*
71B	Adapter mounting screw	4
75	Clamp assembly complete	1
90	Casing gasket	1
131	Seal guard assembly	1
131A	Set screw	1
132	Water cascade assembly	1
M	Motor	1

## BEGINNING THE ASSEMBLY

It is highly recommended that you resort to the diagram on page 6 to verify the assemblies and subassemblies whose directions will follow.

### 1. LEG BRACKET ASSEMBLY

Sets of leg-brackets are optional and can be used to vertically adjust the pump. The size of the brackets (209) and the legs (207) depend upon the NEMA or IEC of the motor. First, complete the primary assembly of the legs and the brackets, using the hexagonal screws (209A) to tighten the legs to the brackets. Next, use the hexagonal screws (209B) to tighten the brackets to the motor (210). You may need to lift the motor to complete this part of the assembly.

### 2. ADAPTER ASSEMBLY

Place the stainless steel adapter on the motor and tighten using four hexagonal screws (71B) with the torque values recommended on **Chart 1**

Torque ft.lb	NEMA Models	IEC Models
20	Frame 56 to 14	Frame 80 to 90
55	Frame 18 to 25	Frame 110 to 180
70	Frame 28	Frame 180
110	Frame 32	Frame 200 to 225

**Chart 1. Torque values for NEMA/IEC adaptor screws**

The adapter should be accompanied by two adapter pins, which normally come preinstalled. If not, insert them in the corresponding drilled holes. These pins serve to set the backplate (11) to the adaptor (71), hooking the backplate onto the adapter pins using the two backplate pins (11F) located on the backplate. Depending upon the pump model and seal type, some backplates do not have pins for reasons of design. The adapter comes with a protective guard (131) which comes attached by an hexagonal screw (131A). It is highly recommended for reasons of safety not to operate the pump if this guard is not placed on the adapter.

### 3. SPACING OF THE IMPELLER AND STUB SHAFT

To set the stub shaft onto the motor, it is necessary to place it at the proper distance. To find this position it is necessary to provide a spacing of seventy one-thousandths of an inch (0.070 in.)

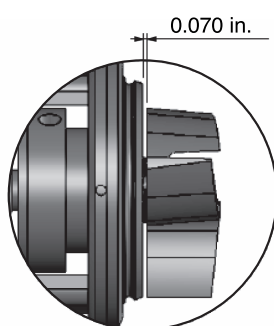

**Figure A**  
Spacing of the impeller  
and stub shaft

between the impeller and the backplate, as shown in **Figure A**.

You can make this adjustment using a caliper or spacing gage.

Depending on the pump model and the seal type, the backplate requires two pins (11F), which serve to hold the backplate in place when mounted on the adaptor.

The backplate pins should always be placed pointing in a counter-clockwise direction so that the backplate does not slip. When handling the backplate be careful not to damage the contact surface of the mechanical seal or the front side of the backplate.

An explanation on how to place the stub shaft onto the motor follows up next. **Chart 2**

The traction between shafts is achieved by friction. By tightening the drive collar bolt (s) **(92A)**, the drive collar plus **(92)** and the stub shaft **(6P or 6E)** closes pressing the motor shaft. To have an optimum performance it is necessary to align the three groups of the assembly: 1.- The motor shaft keyway 2.- the groove 3.- the side groove in the drive collar just as shown in **Figure B**. Slide the drive collar plus thru the stub shaft all the way, then slide both of them thru the motor shaft making the three grooves coincide. Remember the motor shaft key is not needed.

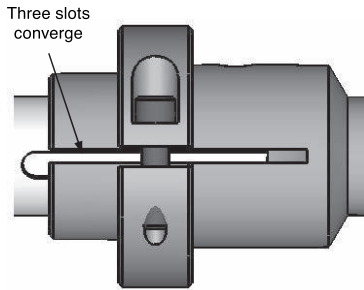

**Figure B**  
Stub shaft plus assembly

Torque ft.lb	NEMA Models	IEC Models
15	Frame 56 to 18	Frame 80 to 112
30	Frame 21 to 25	Frame 132 to 160
40	Frame 28 to 32	Frame 180 to 225

**Chart 2. Torque values for collar drive plus**

### STANDARD STUB SHAFT

Place the backplate onto the adapter and turn it in a counter-clockwise direction, locking the backplate pins **(11F)** onto the adapter pins **(71A)**. If necessary pull out the stub shaft so that it is still mounted onto the motor shaft. Place the retainer **(24)** into the stub shaft so that it recedes completely into its slot and insert the impeller onto the stub shaft, making sure that the retainer falls to one side to secure the impeller. Space the back of the impeller at a distance of 0.070 in. from the face of the backplate and tighten the set screws in order to secure the stub shaft.

### STUB SHAFT PLUS

Next, place the backplate onto the adapter **(71)** and turn it in a counter-clockwise direction, pressing it against the adapter so that the backplate pins **(11F)** lock onto the adapter pins **(71A)**. Place the impeller plus **(2P)** onto the stub shaft after placing the key **(24C)** into the key slot on the shaft. Screw on the impeller nut **(24D)** and tighten until it makes contact with the impeller using a socket (5/8" or 7/8" depending on the model).

You can use a 0.375 in. steel rod in the side hole of the shaft so that the shaft does not turn during assembly. Space the impeller at a distance of 0.070 in. from the face of the backplate.

### STUB SHAFT TIGHTENING

With the .070 in separation, and tighten the collar screws to set the stub shaft. Use **v** to find the appropriate torque values before tightening, remember to align the three parts grooves.

**IMPORTANT:** At this point the adapter is mounted, the stub shaft is fixed on the motor, and the impeller is spaced at a distance of 0.070 in. from the backplate. Take off the impeller and remove the backplate to begin assembling the mechanical seal.

Place the deflector **(40)** in the ridge found on the standard stub shaft. Stub shafts plus do not use a deflector.

#### 4. ASSEMBLING AND INSTALLING THE MECHANICAL SEAL

**MECHANICAL SEALS.** Among the QC, QC plus, and IC plus pump series there exist five types of mechanical seals.

One of these, the “**T21**”, is used exclusively with our IC+ series, specifically in non-sanitary applications. As for the remaining four types, their selection must be based upon the particular application and the properties of the fluid being pumped.

The “**D**” seal is the most common mechanical seal. It is used when the fluid which is going to be pumped is neither corrosive nor abrasive. It is a balanced, external seal, designed to be long-lasting.

The “**F**” seal is exactly the same as the “**D**” seal, but contains a water-cascade assembly to lubricate and cool the seal. The water-cascade assembly is located on one side of the adapter. This seal, although it is sanitary, is very dirty because the coolant tends to drip.

The “**DG**” seal consists of two parts: one stationary and other rotating. The rotating part consists of the same elements as the “**D**” seal. The stationary part consists of one piece which may be carbon silicone, ceramic, or carbon tungsten, and which is placed in a gland ring. This type of seal is used when the fluid to be pumped is abrasive, corrosive, or contains a product which impedes the seal lubrication. The stationary seal is made of a very strong material and is reversible, so flipping the seal is sufficient to continue using it. The “**E**” seal is a double-balanced seal cooled by water. This seal is composed of a stuffing box which is filled with fluid (normally water) to cool the mechanical seal. The “**E**” seal is used in conditions similar to those of the “**DG**” seal but in applications that handle extremely high temperatures (up to 500° F). It can also be used in applications where there exists a vacuum of up to 28 in. of mercury.

**EXTERNAL-BALANCED SEAL TYPES “D” AND “F”.** Locate the following pieces: carbon (**80**), o-ring (**80B**), “D” seal cup (**80A**), “D” seal spring (**80C**), “D” seal drive collar (**80L**), set screws (**80K**), and “D” seal backplate (**11**). Pre-assemble the set screws, making sure they do not penetrate the inner diameter of the stub shaft and set the o-ring into the carbon so that it sits at the back. Next, place the o-ring and carbon together onto the cup so that the cup’s three legs align with the carbon’s slots. Then, fit the spring onto the cup so that the tip of the spring is touching a fourth, folded leg on the cup. If necessary rotate the spring to touch the two pieces. When handling the carbon (**80**), be careful not to bump or scratch the seat of the seal, as this is the face that makes the seal.

For best assembly, the drive collar has a pin or key that should fit into a slot in the cup. Use pressure to insert the drive collar, making sure that the pin aligns with the slot as shown in **Figure C**.

Slide the entire assembly onto the stub shaft.

The o-ring seals the flow of fluid between the pump and the exterior through the mechanical seal by filling the space between the stub shaft and carbon.

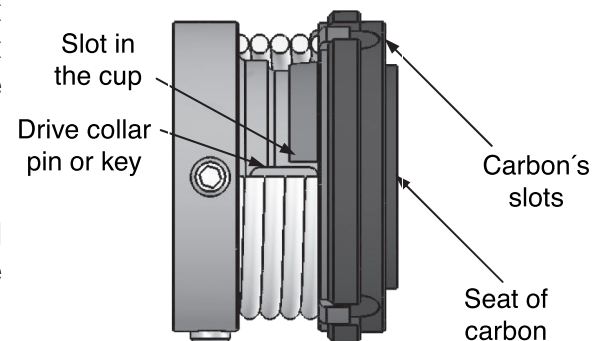

**Figure C**  
Assembling seal type “D”

The seal will provide a resistance when it slides on, so apply pressure until it has gone onto the stub shaft completely. The position of the drive collar against the o-ring and carbon is critical to prevent leaks. Now, assemble the “D” seal backplate (**11**) and fix it with the backplate pins. Push the carbon back with the backplate.

Once the backplate has been placed it is necessary to tighten the “D” seal collar set screws (**80L**). To do this, you must exert a pressure on the drive collar towards the backplate, so that the pin of the drive collar remains aligned with the slot in the cup.

Tighten the set screws once the drive collar has reached its closest point to the o-ring and carbon. The drive collar should stay in its place against the o-ring – against the back – within the limits of the carbon, as shown in **Figure D**. The spring does not compress entirely.

When all parts are in their correct positions, the stub shaft should be able to rotate freely when turned by hand. If it is necessary to use excessive force to turn the stub shaft, check to be sure that the components of the seal have been properly installed and that the drive collar is properly positioned.

The “F” seal is the “D” seal with a water-cascade assembly. The water-cascade assembly (**132**) should be installed on the adapter (**71**), so that the leak falls upon the seal seat of the carbon, lubricating the seal against the backplate.

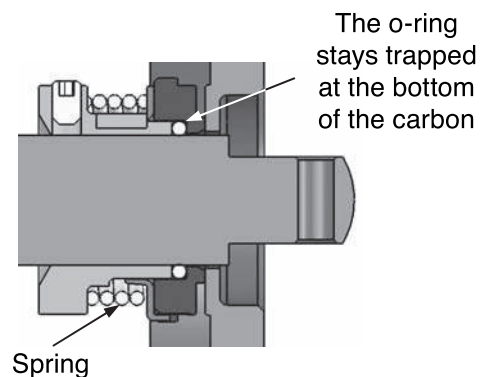

**Figure D**  
Drive collar seal type “D” position

**IMPORTANT:** It is necessary to disassemble some of the pump parts for cleaning and sterilizing. For those Q-Pumps products equipped with “D” seals, if a CIP (Clean-in-Place) instillation is used, disassemble is not necessary. Do not lubricate the seal with grease or oil, the faces of the seals are lubricated by the fluid that is being pumped.

**CLAMPED-IN SEAT SEAL TYPE “DG”.** This seal type consists of two parts: one stationary, and one rotating. The rotating part is the “D” seal assembly. For that reason it is highly recommended that you read the directions above for assembling the “D” seal before continuing. The stationary part consists of the following elements: “DG” seal seat (**80N**), PTFE gasket (**80P**), PTFE gasket (**80R**), “DG” gland ring (**17J**), lock washers (**17M**), bolts/screws gland ring (**17K**), and “DG” seal backplate (**11H**).

**IMPORTANT:** Incorrect spacing between the impeller and backplate can result in dangerous contact between the face of the stationary seal. That contact may wear down the impeller and the seat of the gland ring. A visual inspection following the installation of the impeller is recommended to check the spacing of the impeller and seal.

Take the “DG” backplate (**11H**), turn it around and place the PTFE gasket (**80R**) against the sert face. Next, install the seal seat (**80N**) – which is reversible – followed by the PTFE gasket (**80P**) and finally the gland ring (**17J**). In the seal type “DG”, the seal seat (**80N**) is enclosed by the gland ring, which could be made of either silicone, tungsten, or ceramic

Please remember that the PTFE gaskets (**80P**) and (**80R**) are not interchangeable.

The seal seat (**80N**) is made of a very strong material and therefore is very fragile. It is important to protect the faces of the stationary seal just as with the backplate, against bumps and scratches. Screw the gland ring into the backplate, using the screws (**17K**) and lock washers (**17M**). Screw in the backplate pins (**11F**) to the backplate if applicable. See **Figure E**. Just tighten the screws until the washers are flattened, any tighter and you may crack the stationary seal.

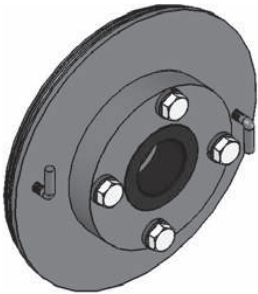

**Figure E**  
Stationary part seal DG

Assemble the “D” seal components onto the stub shaft (as explained in the section regarding the “D” seal) taking care that the o-ring remains inside of the carbon. Once both preassemblies are complete, that of the “DG” seal onto the backplate and that of the “D” seal, take the backplate and push on the “D” seal sliding it onto the stub shaft.

Be very careful not to hit the “DG” seal with the end of the stub shaft. Now, set the backplate onto the adapter. Although space appears to be limited, the spring can be compressed until the drive collar completely touches the o-ring.

Once the backplate is set onto the adapter, push the drive collar against the backplate to compress the spring. Tighten the set screws to set the seal when the spring no further can move.

The efficiency of the “D” and “DG” seals relies upon the position of the o-ring inside the carbon as well as the full compression of the spring. **Figure F**.

“DG” type seal is used to handle fluids that crystallize when allowed to settle for a time. When pumping abrasive or corrosive fluids, combine the “DG” seal with EPDM gaskets. EPDM gaskets are resistant to certain harsh chemicals. For more information, please contact either the plant or your distributor.

**WATER COOLED BALANCED DOUBLE SEAL TYPE “E”.** This mechanical seal is very different from the previous three, although it shares some common components. It consists of two balanced, rotating parts, placed into a stuffing box, which is normally flooded to cool the seal.

The “E” seal consists of the following parts. Find and keep them at hand to make the assembly process easier: stuffing box “E” (**83C**), o-ring (**83E**), machine screw (**83D**), follower (**17**), o-ring (**17B**), machine screw (**17A**), and lock washers (**17C**) for the follower, “E” seal backplate (**11B**), backplate pins (**11F**), spring (**80H**), drive collar “E” (**80J**), set screw drive collar (**80M**), two carbon seals (**80**), two o-rings (**80B**) and two cups (**80G**). It is recommended to have a caliper on hand to assemble this seal precisely.

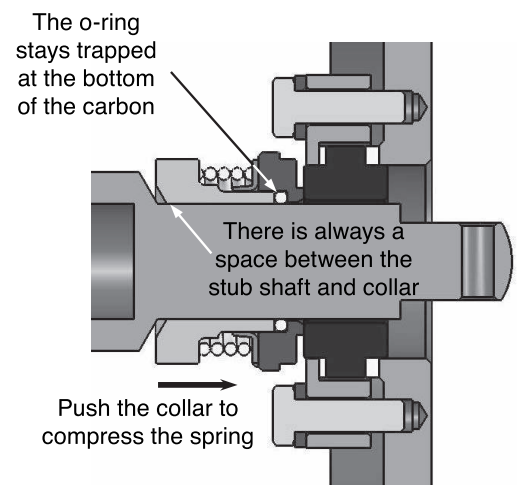

**Figure F**  
Clamped-in seat seal type “DG” assembly

The following instructions assume that the adapter is assembled and that the spacing between the impeller and backplate has been set. If not, we recommend you refer to that section of the assembly directions.

Place the o-ring (17B) in the groove of the follower (17). Attach the backplate pins (11F) to the backplate (11B), take the o-ring (83E) and place it in the slot of the stuffing box (83C) and place both parts against the backplate. Screw on the stuffing box (o-ring in place) to the backplate with the machine screw (83D). Be sure to protect the faces of the backplate during assembly. Pre-assemble the set screws (80M) onto the “E” drive collar (80J) without penetrating the inner diameter.

Slide the “E” drive collar, along with the o-ring, onto the stub shaft (6E), with the o-ring pointing towards the tip of the stub shaft. Pre-assemble the o-rings (80B) in the carbon seals (80), pushing them to the back of the seat. Place each carbon seal onto a cup (80G). These are the two rotating components that will be balanced on the spring (80H) inside the stuffing box (83C).

Be very careful when handling the carbon seals, especially when handling the seal seat, because that face in particular is crucial in maintaining contact between the stuffing box and backplate.

Carefully slide the carbon seal, o-ring and cup, onto the stub shaft, using the “E” drive collar (80J) as a support for the o-ring. The seal seat of the carbon should be able to touch the follower (17). Slide the drive collar onto the stub shaft. Next, we have to secure the drive collar to the stub shaft at the proper distance (Regardless of stub shaft model). For help, refer to **Chart 3** which indicated the spacing values, then take the Vernier caliper and use it to measure that distance as shown in **Figure G**.

Model	Distance X
114	0.621
216	0.572
218/328	0.610
4410	0.956

Chart 3. Distance “X” for every models.

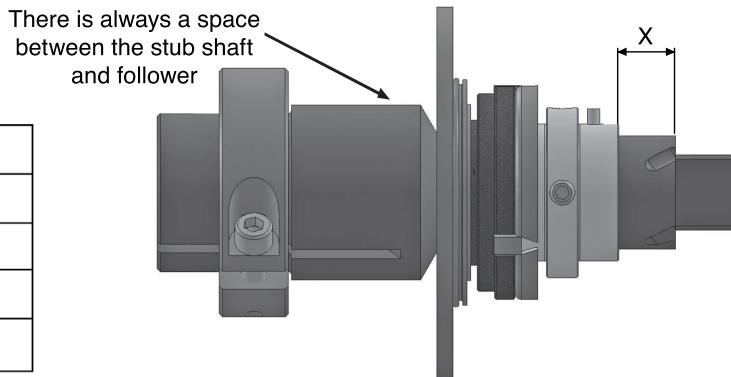

Figure G  
Positioning of the drive collar type “E”

Locate the drive collar “E” (80J) and secure it with the set screws (80M). Place the spring (80H) onto the cup (80G). The drive collar has two pins, which drag both cups along the rotations of the stub shaft. Each cup has a folded leg that initiates traction with the drive collar. Try to place the pins before the legs of the cups, facing in a counter-clockwise direction. **Figure H**.

Now, install the second set of the cup, o-ring and carbon (in that order) onto the stub shaft.

Put the end of the spring into the second cup, just as you did with the first. The seal seat of the second carbon seal should point towards the backplate (11B). Take the sub-assembly of the backplate (11B) with the stuffing box (83C) and place it onto the adapter (71), making sure that the stuffing box does not hit the components mounted on the stub shaft. Push in and rotate the backplate until the pins are locked. If this model does not have backplate pins, place the casing gasket (90) into the slot on the backplate, put on the casing (1) and tighten using the clamp assembly (75) to secure the backplate.

**IMPORTANT:** When you mount the backplate onto the adapter, the seal may supply resistance. If this resistance is too much, check the seal assembly and be sure the drive collar has been located correctly. The efficiency of the “E” seal relies on the proper installation of the drive collar. The space in the stuffing box should contain both carbons in a balanced state of pressures and distances. **Figure I.**

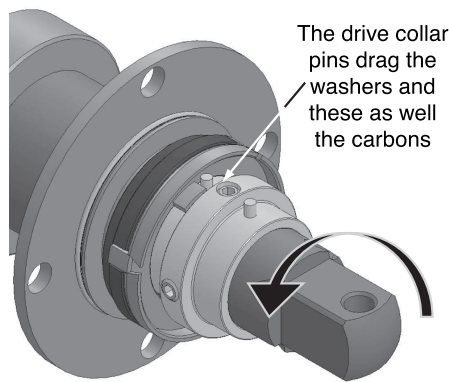

**Figure H**  
The sub shaft must turn counter-clockwise direction

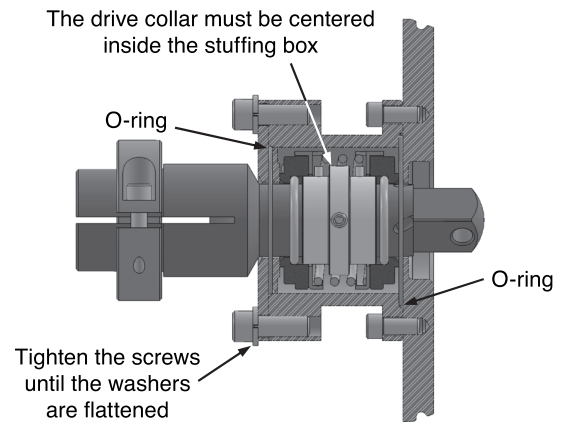

**Figure I**  
Water cooled balanced double seal type “E”

The next step is to close the stuffing box. To do this, you need to pull the follower against the backplate. Use the machine screws (17A) and lock washers (17C) to close it, tightening until the lock washers are flattened. The screws on a circular arrangement can be tighten across and varying positions when screwing.

It is recommended to set the backplate so that the 1/8 NPT drill-holes on the stuffing box, point upward and with a 45° inclination from the horizontal plane, as shown in **Figure J.**

The water should enter through one connection and leave through another, moving through the stuffing box and in the process, cooling it.

The ideal quantity of water will depend upon the temperature of your application. For vacuum applications it is recommended to use a flow of 10 drops per minute, while maintaining a temperature of 176° F inside the seal around 3 gallons per hour are required.

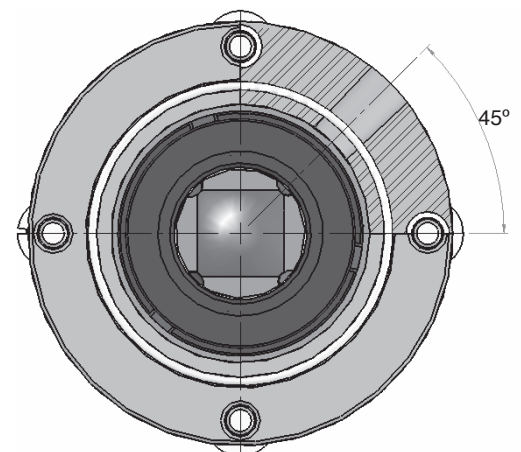

**Figure J**  
Position of the 1/8 NPT drill-holes

**IMPORTANT:** When servicing pumps with “D”, “DG”, “F”, or “E” seals, inspect all disposable parts such as: carbon seals (be sure they have no bumps or scratches), o-rings (they should maintain a circular form and should not be bitten). In the case of abrasive fluids, use EPDM material for all gaskets and o-rings. When dealing with high temperatures, use Viton.

Springs are not subject to wear because of tension or compression, except in extreme cases. Carbon seals made of silicone, tungsten or ceramic are very fragile but resist abrasive and corrosive fluids.

## 5. KIT PLUS ASSEMBLY

**IMPORTANT:** These instructions assume that the adapter has been mounted to the motor and the impeller has been spaced at a distance of 0.070 in. from the backplate. If you have not assembled the sub shaft, please read section 3 before proceeding. Please remember that it is imperative you align the key slot on the motor shaft, the slot on the stub shaft and the slot on the drive collar to properly mount the stub shaft, **Figure B**.

We can easily convert a QC series standard pump to a QC plus series pump with a Kit plus. The QC plus series is 100% sanitary and meets the sanitary regulations set by 3A. The QC plus series uses an improved design that maintains a tighter, more sturdy assembly. To assemble a Kit plus, you must first find the following components: drive collar plus (**92**), bolt drive collar (**92A**), stub shaft plus (**6P**), stub shaft key (**24C**), back impeller gasket (**91A**), front impeller gasket (**91B**), impeller plus (**2P**) and impeller nut (**24D**).

**IMPORTANT:** In some cases, the front and back gaskets are interchangeable (only models 218/328 and 4410). The Kit plus is compatible with “D”, “DG”, “F”, and “E” seals. The only differences are the method of installing the stub shaft to the motor and the retention of the impeller. **Figure K**.

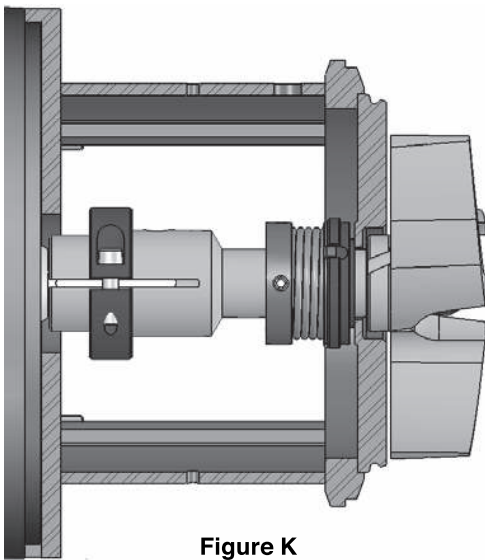
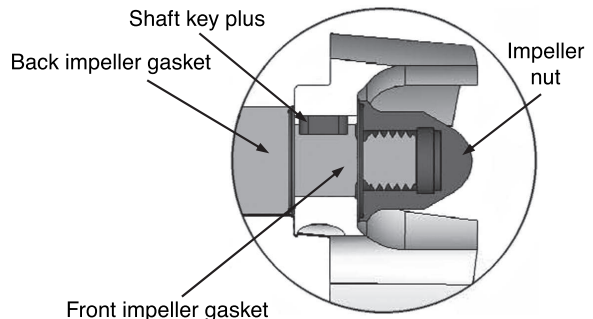

**Figure K**  
Kit plus with seal type “D”

Tighten the impeller nut using a torque wrench. Use 20 ft-lb for 114+ model and 40 ft-lb for the rest of models. **Figure L**.

**IMPORTANT:** Before continuing with the assembly of the Kit plus, put together the seal type that you are going to use (Please see section 4).

Once you have put together the seal and secured the backplate, place the back gasket for the impeller plus (**91A**) into the groove on the stub shaft plus (**6P**). Next, place the shaft key (**24C**) into the key slot on the stub shaft. Slide the impeller plus (**2P**) onto the stub shaft and past the key, using the impeller key slot, making sure that the back gasket remains in its groove. Insert the front impeller gasket (**91B**) into the groove on the impeller nut (**24D**). Screw the impeller nut onto the stub shaft making sure that the front gasket remains in the groove on the impeller nut.



**Figure L**  
Gaskets isolate the fluid from the thread and key

**IMPORTANT:** Never start the pump without the stub shaft key in place, as doing so may lead to friction between the impeller and stub shaft, causing seizure between the parts. Do not forget to adjust the screws and impeller nut before starting up the pump. If you are using CIP (Clean-in-Place) installations, there is no need to disassemble the Kit plus. The threads of the stub shaft and impeller nut are sealed from fluid entry thanks to the front and back gaskets, and therefore are sanitary.

## 6. INDUSTRIAL T21 SEAL ASSEMBLY – IC+ SERIES

The IC plus series (industrial centrifugal pumps) is another configuration of the QC and QC+ series designed for non-sanitary applications. The IC plus series does not meet 3A sanitary regulations. An IC plus series pump is composed of the same parts as a standard QC series pump, but requires the plus Kit to set the stub shaft and install the impeller. It also uses an industrial internal seal – T21 – and a specially designed backplate. The T21 seal generally comes as a Kit and is disposable, so if one of the parts is damaged you need to replace the entire Kit.

**IMPORTANT:** These assembly instructions assume that the adapter has been mounted to the motor and the impeller has been placed at a distance of 0.070 in. from the backplate. If the stub shaft has not yet been assembled, please return to section 3 before continuing. To assemble the T21 seal (95), please identify the following parts:

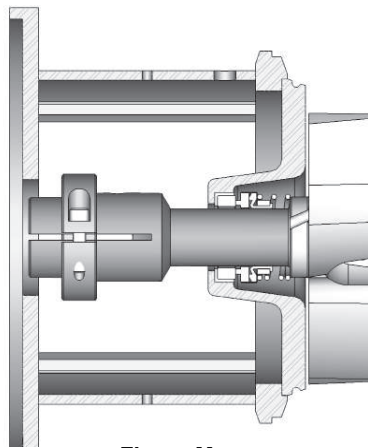

**Figure M**  
Industrial seal type T21

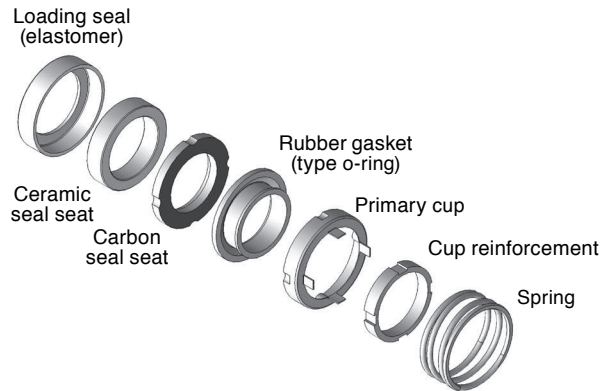

**Figure N**  
Seal Components

The ceramic seal, which is reversible, goes inside the lodging, which goes inserted into the industrial backplate (11P). Place the reversible cup reinforcement into the primary cup so that the legs align with the slots. Place the rubber gasket (o-ring) into the primary cup so that it sits at the back and holds in the cup.

Now, place the carbon into the cup, taking care not to damage the seal seat, so that the carbon aligns with the groove in the cup. Place the backplate – with the ceramic seal seat in place – on the adapter, taking care not to bump the seal on the stub shaft threads.

Slide the sub-assembly of the carbon and cup onto the stub shaft until it touches the ceramic seal. Place the shaft key (24C) and back gasket (91A) in their respective slots. Force the spring into the cup and slide the plus impeller (2P) over the shaft key and onto the stub shaft and push. Place the front gasket (91B) in the groove on the impeller nut (24D) and tighten the assembly.

## 7. GENERAL ASSEMBLY INSPECTION

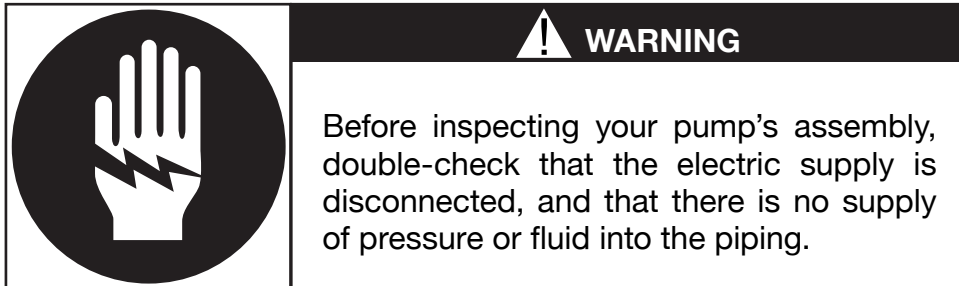

Before continuing please check that all bolts/screws and set screws have been tightened. Rotate the stub shaft by hand, using the impeller. The stub shaft should rotate easily. If something is interfering with its rotation, inspect all parts to verify correct assembly (stub shaft, seal, backplate, etc).

## 8. IMPELLER RETENTION

**IMPELLER RETENTION ON STANDARD STUB SHAFTS.** Find the following parts: impeller (**2**), retainer (**24**) and standard stub shaft (**6E**).

Place the retainer into the drilled hole atop the stub shaft so that it is completely recessed. When you have placed the impeller at the back, make sure that the retainer falls to lock in the impeller. **Figure N.**

**IMPELLER RETENTION ON STUB SHAFTS PLUS.** Find the following parts: impeller plus (**2P**), impeller gaskets (**back, 91A**) and (**front, 91B**), impeller nut (**24D**), shaft key (**24C**) and stub shaft plus (**6P**).

Place the shaft key into the stub shaft and place the back impeller gasket (**91A**) into the groove on the shaft. Slide the impeller onto the shaft until it reaches the back and place the front gasket (**91B**) onto the impeller nut, screwing the nut (**24D**) onto the impeller. Make sure the gaskets stay in place. **Figure P.**

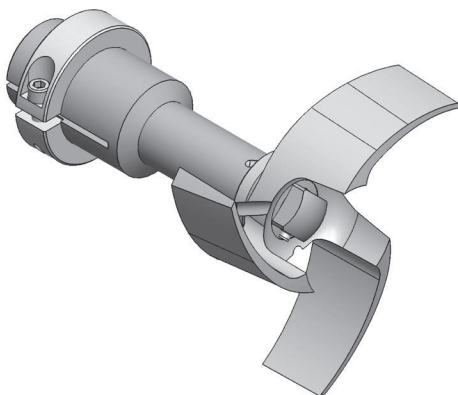

**Figure O**  
Standard stub shafts  
and impeller pin

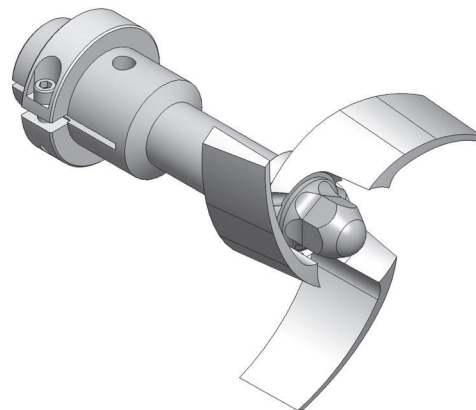

**Figure P**  
Stub shaft plus  
and impeller nut

## 9. CASING ASSEMBLY

Once the impeller has been installed, the casing must be mounted. Place the casing gasket (90) onto the groove on the backplate (**11, 11B, 11H or 11P**), depending on the seal type. Take the casing (**1**) and place it onto the adapter, positioning the discharge at the desired location. Take the clamp assembly (**75**) and place it around the casing. Tighten the clamp to close the casing so that it is level around the perimeter. A rubber mallet may be helpful when installing the casing.

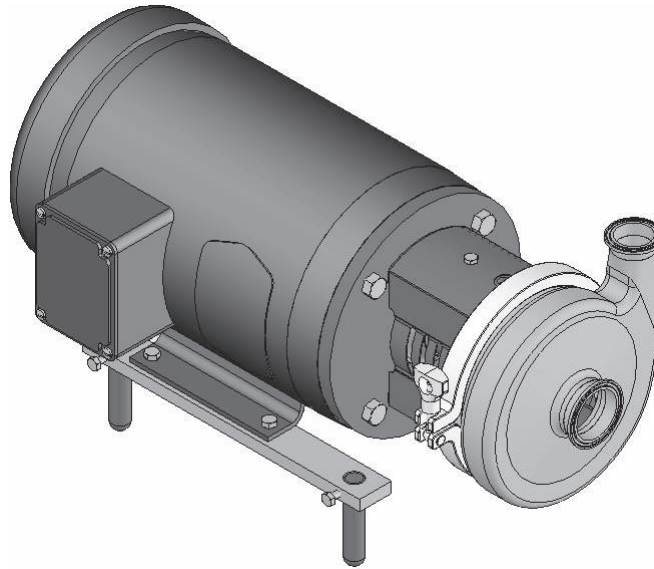

## 10. BEFORE TURNING ON THE PUMP

- Check that the motor turns in a counter-clockwise direction.
- Keep the suction line flooded and the mechanical seal lubricated with the fluid which is going to be pumped. Never operate the pump when dry or it may damage the seal.
- Maintain a sufficient NPSH available in the suction line (please see the section on piping).

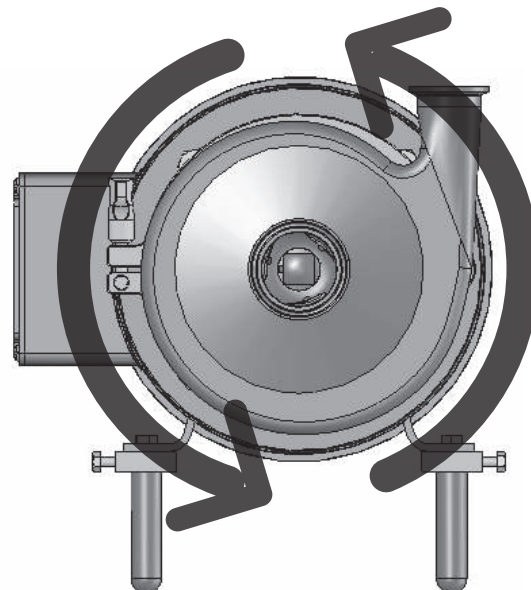



## **QUICK GUIDE FOR SOLVING COMMON PROBLEMS**

Q-Pumps products are relatively easy to maintain with the exception of the sanitary process. Just as with any other element of machining, problems may arise. This section offers a guide for identifying and correcting the majority of the pumping problems. For problems with you motor, contact the manufacturer directly for best assistance.

The following table illustrates the problems and probable causes, assuming that the pump was correctly selected for a specific application. If none of the listed solutions provided in the table resolves the problem, the most likely cause is cavitation. Cavitation may be caused by an incorrect pump selection and its symptoms include: excessive noise, insufficient pressure, fluid leak and vibration. If these symptoms are present, please re-evaluate your application.

<b>1. NO FLOW</b>	<b>SOLUTIONS</b>
a) Motor speed too low. b) Incorrect rotation direction. c) Obstruction in discharge piping or closed valves.	a) Check electric connections and motor. b) Reverse one of the motors three phases. If direction does not change, contact manufacturer. c) Remove obstruction and open valves.
<b>2. INSUFICIENT FLOW</b>	
a) Motor speed too low. b) Incorrect rotation direction. c) Obstruction in discharge piping or closed valves. d) Impeller damaged.	a) Check electric connections and motor. b) Reverse one of the motors three phases. If direction does not change, contact manufacturer. c) Remove obstruction and open valves. d) Replace impeller.
<b>3. EXCESSIVE POWER CONSUMPTION</b>	
a) Motor speed too high. b) Impeller damaged. c) Motor shaft is bended or worn.	a) Motor wires are bad, replace motor. b) Remove casing and replace impeller. c) Replace motor shaft.
<b>4. EXCESSIVE NOISE</b>	
a) Magnetic problem with motor. b) Motor bearings damaged. c) Foreign particles in impeller. d) Impeller damaged. e) Cavitation.	a) Consult motor manufacturer. b) Replace bearings. c) Remove casing and extract particles. d) Replace impeller. e) Check system's available NPSH. d) Cavitation.
<b>5. EXCESSIVE VIBRATION</b>	
a) Pump is not leveled. b) Impeller damaged. c) Piping lacks supports. d) Cavitation.	a) Level the pump. b) Replace impeller. c) Support suction and discharge piping. d) Check system's available NPSH.
<b>6. FLUID LEAK</b>	
a) Disposable o-rings. b) Disposable carbons. c) Insufficient seal compression. d) Damaged casing suction/discharge. e) Disposable casing gasket. f) Loose clamp assembly.	a) Replace o-rings. b) Replace carbons. c) Replace spring. d) Replace casing. e) Replace casing gasket. f) Tighten clamp assembly.



Operation and Maintenance Manual  
Centrifugal pump  
QC Series

**Acceso "A" #103, Fraccionamiento Industrial  
Jurica, Querétaro, Qro., México. C.P. 76130  
Call: +52 (442) 218 4570 / 218 7400  
Fax: +52 (442) 218 4577**

[support@qpumps.com](mailto:support@qpumps.com)

[www.qpumps.com](http://www.qpumps.com)